

Please read and save this Repair Parts Manual. Read this manual and the General Operating Instructions carefully before attempting to assemble, install, operate or maintain the product described. Protect yourself and others by observing all safety information. The Safety Instructions are contained in the General Operating Instructions. Failure to comply with the safety instructions accompanying this product could result in personal injury and/or property damage! Retain instructions for future reference.

# 3/8-Inch Bronze Coolant Pumps

Refer to form 1808-634-00 for General Operating and Safety Instructions.

## Description

These coolant/recirculating pumps are heavy-duty units designed for a variety of applications involving evaporative coolers, fountains, laboratories, bilge pumping, etc. Each pump is equipped with motor, 36" 3-conductor cord, brass tube column, and bronze base and impeller. Handles liquids from 40° to 200° F (4° to 93° C).

For use with non-flammable liquids compatible with pump component materials. The motor on this pump is not intended to be submersed in liquid, the liquid level should be at least 2" below motor bottom.

## Performance Chart

| Outlet Piping | GPM of Water at Total Head in Feet |     |     |     |     | Shut-Off |
|---------------|------------------------------------|-----|-----|-----|-----|----------|
|               | 1'                                 | 3'  | 5'  | 8'  | 10' |          |
| 3/4" ID       | 8.3                                | 7.1 | 6.0 | 3.5 | 0.8 | 10.2 ft. |
| 1/2" ID       | 6.7                                | 5.4 | 4.2 | 2.0 | 0.6 | 10.2     |
| 3/8" ID       | 5.0                                | 3.3 | 2.2 | 1.2 | 0.3 | 10.2     |

## Dimensions (Inches)

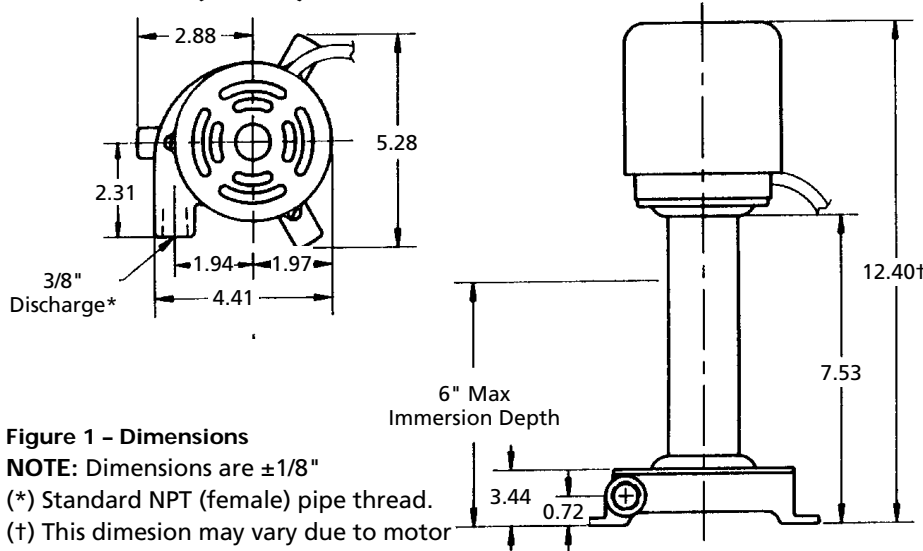

Figure 1 - Dimensions

**NOTE:** Dimensions are  $\pm 1/8"$   
 (\*) Standard NPT (female) pipe thread.  
 (t) This dimension may vary due to motor manufacturer's specifications.

## Specifications

Motor . . . . . 1/25 HP, Totally enclosed fan-cooled  
 Power supply . . . . 115V, 60 Hz (4230-97)  
 . . . . . 230, 60 Hz (4231-97)  
 Discharge outlet . . . . . 3/8" NPT  
 Height (overall) . . . . . 12 1/2"  
 Weight (appx.) . . . . . 9 lbs.

**NOTE:** Driver data is subject to change without notice, see label on driver for actual specifications.

## Operation

1. Liquid level should always be at least 2" below the bottom of the motor. Motor is NOT submersible.
2. Activate the unit. No controls are

supplied with this unit. Dry running will not harm pump or motor.

3. Familiarize yourself and others with all controls for this pump. Learn how to stop pump/motor quickly in an emergency.

## Maintenance

**▲ WARNING** *Make certain that the unit is disconnected from the power source before attempting to service or remove any component! Failure to do so could result in electrical shock.*

## LUBRICATION

Remove pump from installation and lay on side. Squeeze or remove rubber grommets covering oiling holes on the side of the motor (See Figure 2) and put in 4 or 5 drops of SAE 20W oil or its equivalent every 6 months. Let pump lay on its side for a few minutes to let the oil saturate the bearing. Do not over-oil. Over-oiling can shorten motor life. Replace rubber grommets.

## IMPELLER MOTOR REPLACEMENT PROCEDURE

1. Remove base volute housing (Ref. No. 9) by removing three mounting screws (Ref. No. 5).
2. Remove impeller from impeller tubing (Ref. No. 7). If it doesn't come off easily, cut it off.
3. Unscrew motor adapter (Ref. No. 2) from motor exposing impeller tube without impeller.
4. Cut tubing of impeller assembly diagonally so that it comes off motor shaft. Do not cut motor shaft.
5. When replacing a new motor a new impeller assembly must also be installed.
6. Reassemble pump parts (Ref. Nos. 2, 4, and 6) back onto motor, tightening



**For Repair Parts, contact dealer where pump was purchased**

Please provide following information:

- Model number
- Serial number (if any)
- Part description and number as shown in parts list

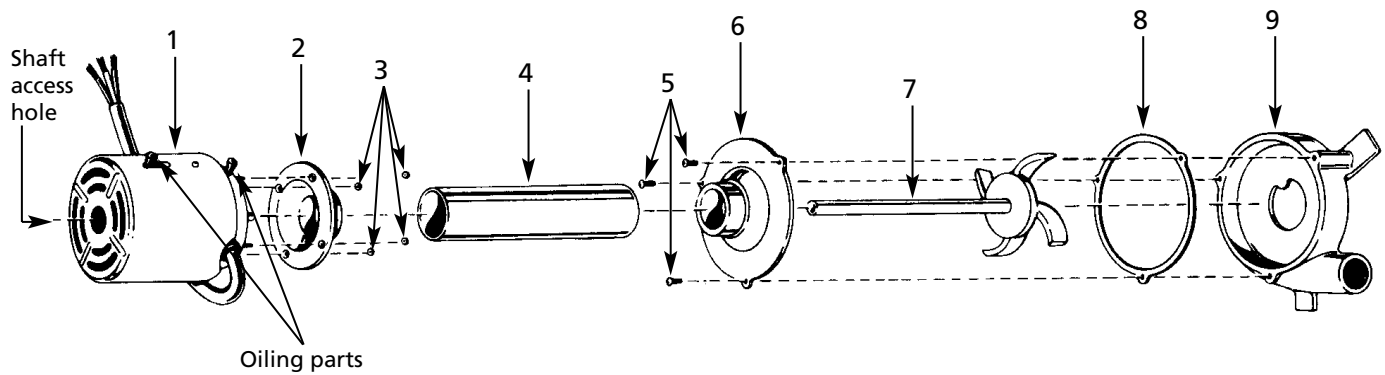

Figure 2 - Repair Parts Illustration

**Repair Parts List**

| Reference Number | Description                     | Part Number | Quantity |
|------------------|---------------------------------|-------------|----------|
| 1                | Motor (4230-97)                 | 1626-055-00 | 1        |
|                  | Motor (4231-97)                 | 1626-056-00 | 1        |
| 2                | Motor adapter                   | 2200-002-01 | 2        |
| 3                | #8-32 UNC Hex nut               | *           | 4        |
| 4                | Tube column                     | 2200-003-00 | 1        |
| 5                | #8-32 UNC x 1/2" Mounting screw | *           | 3        |
| 6                | Volute cover                    | 2201-000-01 | 1        |
| 7                | Impeller assembly               | 2200-006-90 | 1        |
| 8                | Volute gasket                   | 2200-005-00 | 1        |
| 9                | Volute                          | 2200-000-01 | 1        |

(\* Standard hardware item, available locally.

