



SERIES PG

INDUSTRIAL DUTY

Engine Driven High Pressure Pumps

Product Features

- Cast iron or aluminum construction.
- Single and two stage models.
- Dual volute design on single stage model.
- Stainless steel impellers on two stage models.
- Buna mechanical seal and O-ring.
- 1-1/2" FNPT ports.
- Self-priming to 20 ft.
- 3-1/2 to 6 hp B&S or Honda engines.
- Pumps include heavy duty roll frame.
- Wheel kits available on some models.

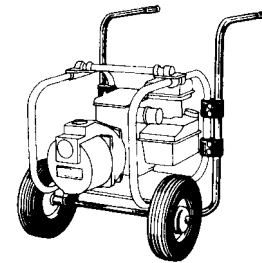
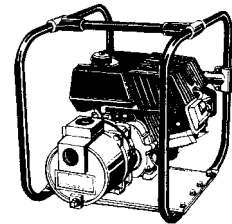
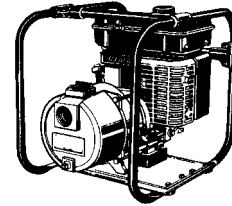

The **MEGGA** line of engine driven high pressure pumps is designed for services such as irrigation, spraying, dewatering, fire fighting, water supply and pressure boosting. Single stage models feature replaceable cast iron dual volutes and semi-open 1/8" solids handling impellers. Two stage models feature cast iron diffusers and fully closed stainless steel impellers for maximum high pressure efficiency.

MEGGA engine driven high pressure pumps are your reliable, cost effective and low maintenance solution. For use with non-flammable fluids compatible with component materials.

Performance of Engine Driven High Pressure Pumps

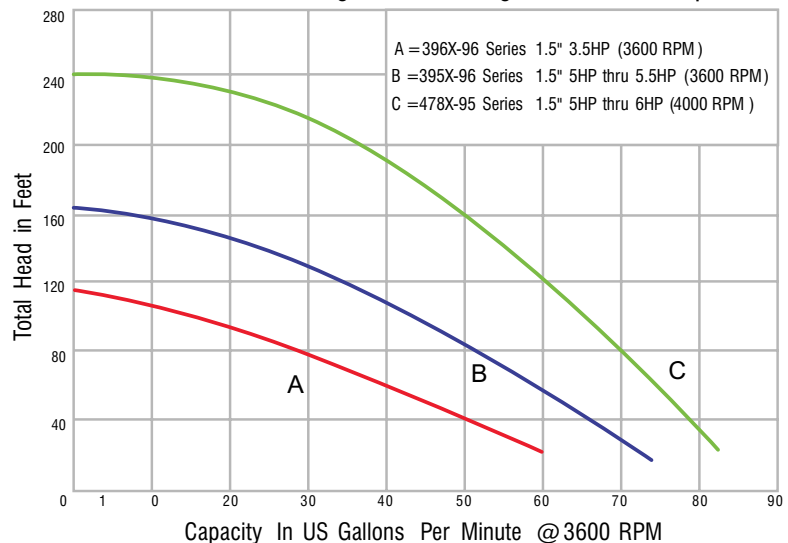

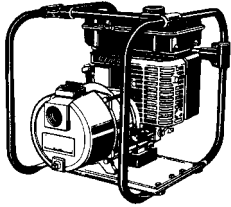

1-1/2" High Pressure Pumps (Single Stage)

Model#	Driver	Ship Wt.	Run Time	Tank Size
3960-96	3.5 HP B&S	50 Lbs.	180 Min.	3 Qt.
3950-96	5.5 HP B&S INTEK+	69 Lbs.	90 Min.	3 Qt.

Cast Aluminum Construction with Cast Iron Volute

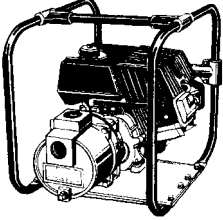

1-1/2" High Pressure Pumps (2 Stage)

Model#	Driver	Ship Wt.	Run Time	Tank Size
4787-95	6.5 HP B&S INTEK PRO+	104 Lbs.	100 Min.	3 Qt.
4789-95	5.5 HP Honda+	99 Lbs.	100 Min.	3.8 Qt.

Cast Iron Construction with Stainless Steel Impellers

2 Stage Models Feature Oil Alert on Engines

* Based on a Full Tank of Gas @ Maximum RPM (Approx.)

+ Overhead Valve Engine (OHV)

Optional Wheel Kits

for roll frame pumps (3.5 thru 9 HP)

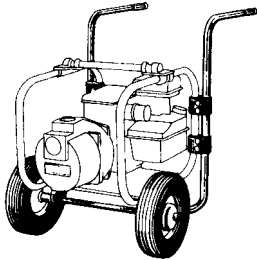

Model #	Features	Ship Wt.
A734-90	Includes 10" semi-pneumatic tires on steel wheels with cast iron clamps and steel handle for universal mounting to frame.	26 lbs.
A735-90	Includes 16" pneumatic tires on steel wheels with cast iron clamps and steel handle for universal mounting to frame.	29 lbs.

Standard Features

- Two NPT Pipe Nipples
- Buna-N Mechanical Seal and O-Ring
- Optional Viton® Mechanical Seal and O-Ring Available
- Self-priming to 20 ft. with Built In Check Valve
- Cast Iron Replaceable Volute/Diffuser
- Semi-open, Clog Resistant Aluminum Impellers on Single Stage Models
- Stainless Steel High Efficiency Closed Impellers on Two Stage Models
- Maximum Temperature 180° F
- Maximum Working Pressure 150 PSI
- Single Stage Models Deliver up to 70 PSI and 4500 GPH
- Two Stage Models Deliver up to 103 PSI and 5000 GPH

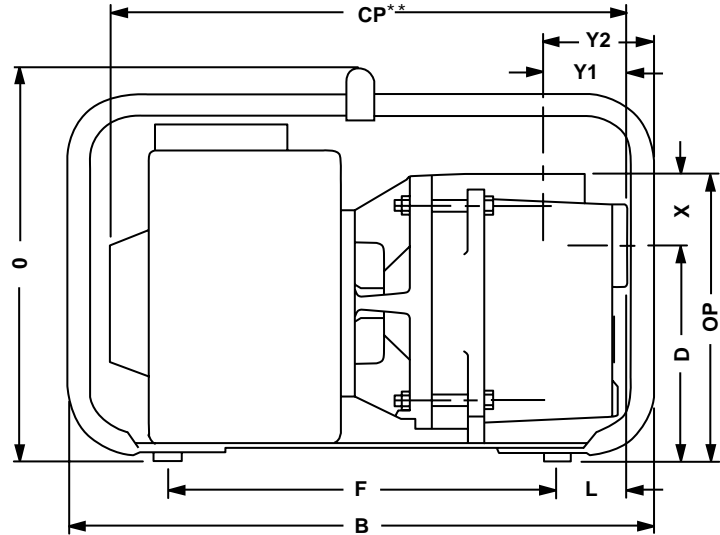
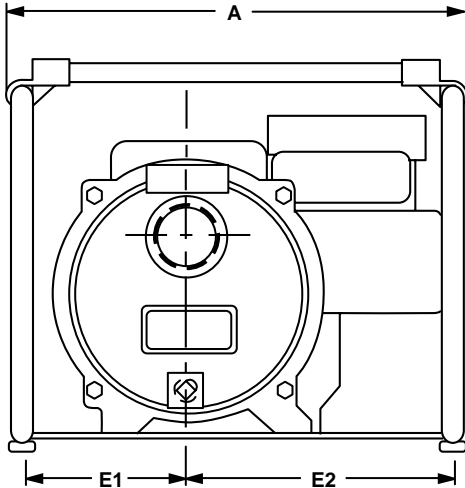

MODEL#	HP	A	B	CP**	D	E1	E2	F	L	O	OP	X	Y1	Y2
396X-96	3 or 4 HP	15.5	19.0	17.5	6.8	5.0	10.0	8.5	4.5	16.0	9.5	2.6	3.5	4.6
395X-95	5 or 6 HP	16.5	22.0	19.0	8.5	5.0	10.0	8.5	6.0	19.3	11.5	3.0	3.5	5.3
478X-95	5 or 6 HP	16.5	22.0	19.0	7.1	5.1	9.9	8.5	6.5	19.4	9.7	2.6	3.1	4.1

(**) This dimension may vary due to engine manufacturer's specifications.

NOTE: Dimensions have a tolerance of ±1/8".

