



SERIES PG

INDUSTRIAL DUTY

Engine Driven Trash Pumps

Product Features

- Cast iron or aluminum construction.
- Buna mechanical seal and O-ring.
- 2", 3" or 4" FNPT ports.
- Self-priming to 20 ft.
- Semi-open, non-clog impellers.
- 3-1/2 to 16 hp B&S, Honda or Vanguard engines.
- Handles solids up to 2" diameter.
- Pumps include heavy duty steel base or roll frame.
- Wheel kits available on some models.

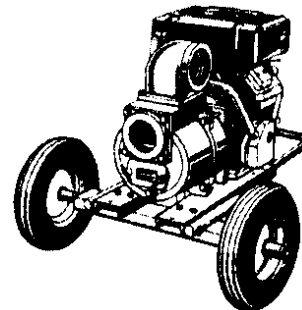
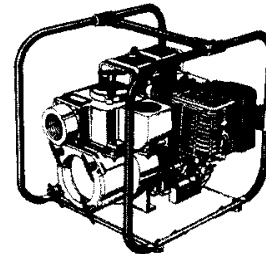
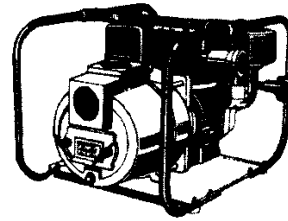

The **MEGGA** line of engine driven trash pumps is designed for applications requiring high flow efficiency along with solids and debris handling capability. Pumps are constructed of heavy duty cast components and feature easily replaced/removed cast iron volutes, impellers and wearplates. Simple cleanout design permits the removal of debris without disconnecting piping. Pumps are available with side valve or overhead valve engines from various manufactures. An electric start option is available on some models.

MEGGA engine driven trash pumps are your reliable, cost effective and low maintenance solution. For use with non-flammable fluids compatible with component materials.

Performance Engine Driven Trash Pumps

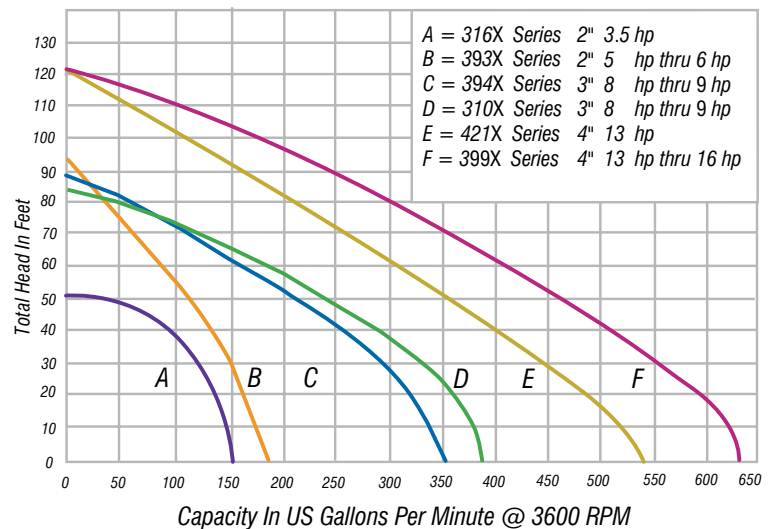

2" Engine Driven Trash Pumps



Model#	Driver	Ship Wt.	Run Time	Tank Size
3163-95	3.5HP B&S	76 lbs.	150 min.	3.0 qt.
3930-95	6.5HP B&S INTEK I/C*	110 lbs.	120 min.	4.0 qt.
3932-95	5.5HP HONDA*	104 lbs.	100 min.	3.8 qt.
3935-95	5.5HP B&S INTEK	106 lbs.	106 min.	3.0 qt.

Construction - Cast Iron

Solids Handling - 1"

3" Engine Driven Trash Pumps



Model#	Driver	Ship Wt.	Run Time	Tank Size
3941-96	8HP B&S Intek PRO*	143 lbs.	90 min.	4.0 qt.
3943-96	9HP HONDA*	153 lbs.	100 min.	6.4 qt.
3944-96	9HP HONDA***	185 lbs.	100 min.	6.4 qt.
3946-96	8HP B&S I/P***	174 lbs.	90 min.	6.0 qt.
3947-96	9HP VANGUARD*	167 lbs.	100 min.	6.4 qt.

Construction - Cast Aluminum w/Iron Wearparts Solids Handling - 1-1/2"

3" Premium Engine Driven Trash Pumps

feature additional cleanout covers for heavy debris application



Model#	Driver	Ship Wt.	Run Time	Tank Size
3100-96	8HP B&S Intek PRO*	151 lbs.	90 min.	4.0 qt.
3103-96	9HP HONDA*	169 lbs.	100 min.	6.4 qt.
3104-96	9HP HONDA***	179 lbs.	100 min.	6.4 qt.
3106-96	8HP B&S I/P***	169 lbs.	90 min.	6.0 qt.
3107-96	9HP VANGUARD*	161 lbs.	100 min.	6.4 qt.

Construction - Cast Aluminum w/Iron Wearparts Solids Handling - 1-1/2"

Optional Wheel Kits

for frame mounted pumps (3.5 thru 9HP)



Model#	Features	Ship Wt.
A734-90	Includes 10" semi-pneumatic tires on steel wheels with cast iron clamps and steel handle for universal mounting to frame.	26 lbs.
A735-90	Includes 16" pneumatic tires on steel wheels with cast iron clamps and steel handle for universal mounting to frame.	29 lbs.

4" Premium Engine Driven Trash Pumps



Model#	Driver	Net Wt.	Run Time	Tank Size
3993-96	16HP B&S VANGUARD***	294 lbs.	100 min.	9.0 qt.
3994-96	13HP HONDA***	299 lbs.	80 min.	6.9 qt.
4210-96	13HP B&S VANGUARD*	238 lbs.	90 min.	6.0 qt.

Construction - Cast Aluminum w/Iron Wearparts Solids Handling - 2"

* Oil Alert Included

**12V DC Electric Start (battery not included)

Standard Features

- > Two NPT Pipe Nipples
- > Buna-N/Silicon Carbide Mechanical Seal
- > O-Ring Casing Seal
- > Self-primes to 20 ft. with Built In Check Valve
- > Stainless Steel Shaft Sleeve
- > Steel Suction Strainer Included
- > Cast Iron Replaceable Volute/Wearplate & Impeller
- > Maximum Temperature 180° F
- > Maximum Working Pressure 60 PSI
- > 2" & 3" Models Include Steel Roll Frame
- > 4" Models include Wheel Kit and Base Rails
- > Intek, Vanguard and Honda Engines are Overhead Valve (OHV) Designs

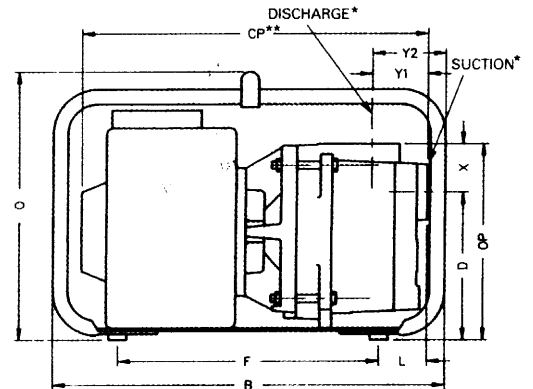

2" & 3" Models

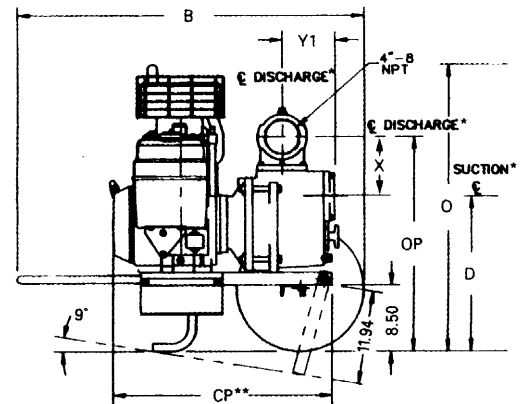

4" Models

(*) Standard NPT (female) pipe thread.

(**) This dimension may vary due to engine manufacturer's specifications.

NOTE: Dimensions have a tolerance of ±1/8".



MODEL#	WIDTH	B	CP**	D	F	L	O	OP	X	Y1	Y2
3163-95	15.5	19.0	17.5	6.8	8.5	4.5	16.0	9.5	2.6	3.2	4.6
393X Series	17.0	22.0	19.0	8.5	8.5	6.0	19.3	11.5	3.0	3.5	5.3
394X Series	21.3	27.3	25.5	11.0	15.0	6.0	23.0	14.5	3.5	5.0	6.0
310X Series	21.3	27.3	20.1	11.6	15.0	6.0	23.0	13.6	2.0	8.3	11.3
421X Series	37.5	44.1	27.4	19.6	N/A	N/A	36.3	27.5	7.8	6.5	N/A
399X Series	37.5	44.1	27.4	19.6	N/A	N/A	36.3	27.5	7.8	6.5	N/A