



SERIES PG

INDUSTRIAL DUTY Self-Priming Utility Pumps

Models 4850-97 & 4851-97:

- **Cast Bronze Construction**
- **Buna-N Mechanical Seal and O-Ring**
- **3/4" NPT Suction and Discharge Ports**
- **Maximum Working Pressure 50 PSI**
- **Maximum Temperature 180° F**
- **Meets U.S. Coast Guard (USCG) Electrical Standards for Ignition Protection on Gasoline Powered Vessels**
(Title 33, Chapter 1, Part 183, Subpart 1)
- **Available in 1/12 HP, 12V DC (4850-97) or 1/12 HP, 115VAC (4851-97) Motors**
- **Maximum Suction Lift is 4 ft.**

MEGGA Self-priming Bronze Centrifugals are compact and designed for a wide range of dewatering/recirculating applications including marine, salt water aquaculture and live well tanks. Model 4850-97 is fitted with a 1/8 HP, 12V DC, 3700 RPM motor while Model 4851-97 is fitted with a 1/12 HP, 115VAC, 3450 RPM motor. Both drivers meet U.S. Coast Guard standards for ignition protection on gasoline powered vessels.

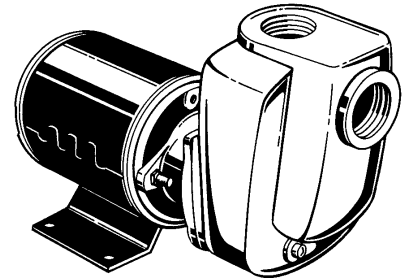
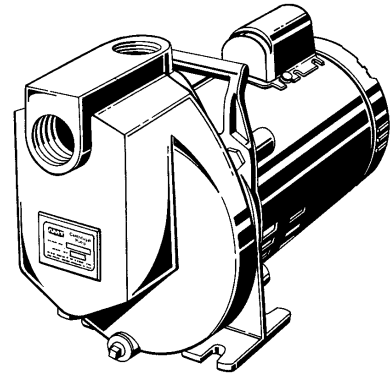

Model 4292-96:

- **Cast Aluminum Construction**
- **Buna-N Mechanical Seal and O-Ring**
- **1" NPT Suction and Discharge Ports**
- **Carry Handle**
- **Maximum Working Pressure 75 PSI**
- **Maximum Temperature 180° F**
- **Includes (2) Garden Hose Adapters**
- **1/2 HP NEMA 56J Open Drip Proof (ODP) Motor with 8 ft. 115VAC Cord**
- **Maximum Suction Lift is 6 ft.**

Model 4292-96 is designed to be portable and handle many water transfer services including storm drainage, emergency water supply, wash down and swimming pool/spa tub draining. Self-cleaning, semi-open impeller handles solids up to 1/8" diameter. Built-in carrying handle for ease of transport and two 1" x 3/4" garden hose adapters included. Pump is coupled to a 1/2 HP ODP motor complete with 115 VAC line cord and plug.

MEGGA Self-priming Utility pumps are reliable, cost effective, low maintenance and readily available. For use with non-flammable fluids compatible with pump component materials.

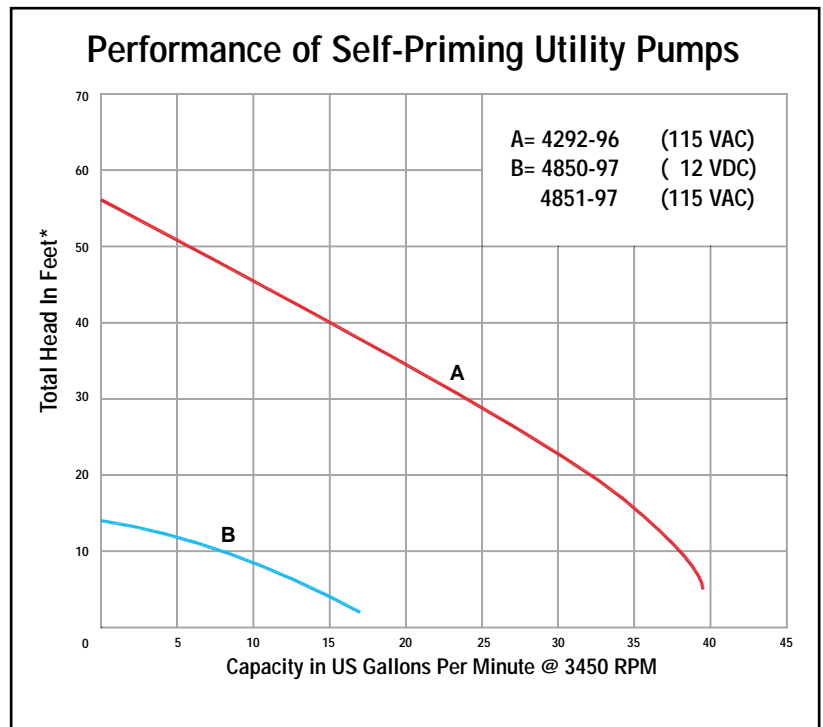

Self-Priming Utility Pumps

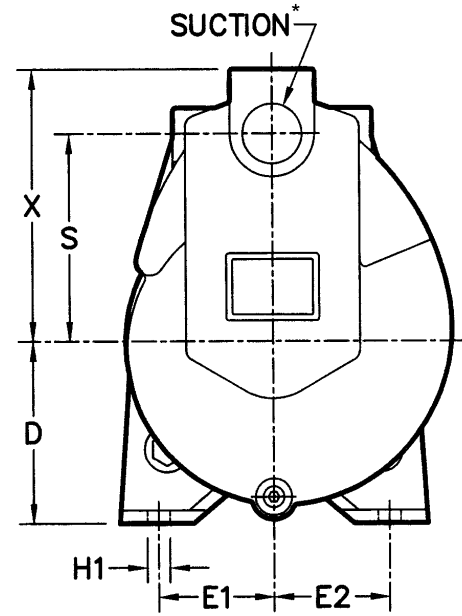
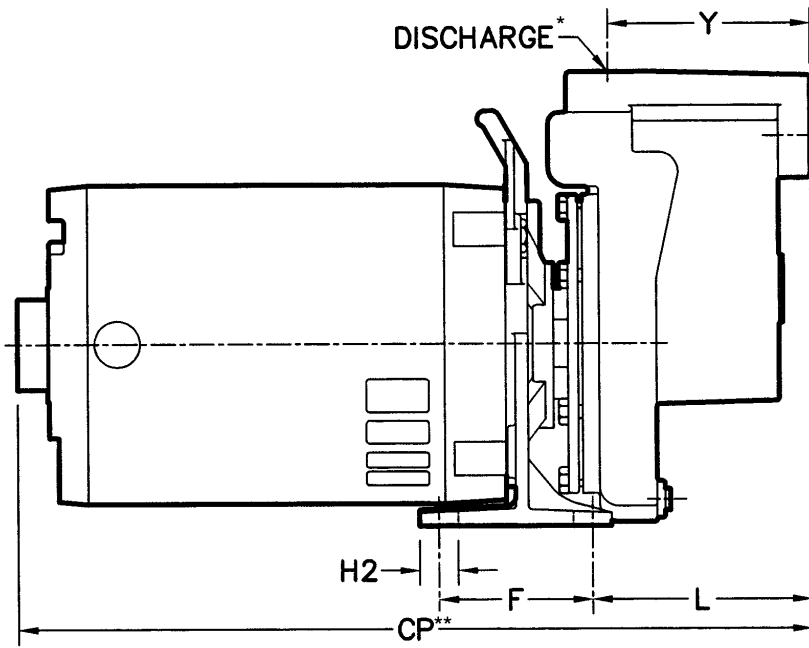

Pump Dimensional & Specification Data

Model No.	HP	PH	ENC	Voltage	Full Load Amps	SUC*	DIS*	CP**	D	E1	E2	F	H1	H2	L	S	X	Y	Ship Wt.
4850-97	1/8	-	TENV	12.8V DC	11	3/4"	3/4"	8.7	1.7	1.7	1.7	1.9	0.2	0.2	5.2	3.4	2.3	2.0	9 Lbs.
4851-97	1/12	1	TENV	115V AC @ 60 Hz	2	3/4"	3/4"	11.6	2.4	1.7	1.7	1.7	0.9	0.3	5.1	3.3	2.3	2.0	17 Lbs.
4292-96	1/2	1	ODP	115V AC @ 60 Hz	10 / 5	1"	1"	16.1	3.5	2.2	2.2	2.7	0.4	0.7	4.4	4.0	5.2	3.9	21 Lbs.

(*) Standard NPT (female) pipe thread.

(**) This dimension may vary due to motor manufacturer's specifications.

NOTE: Dimensions have a tolerance of $\pm 1/8"$.

NOTE: Electric supply for ALL AC motors must be within $\pm 10\%$ of nameplate voltage rating (e.g. 230V $\pm 10\%$ = 207 to 253).

Standard Features

Model 4850-97 & 4851-97:

- Cast Bronze Construction
- Buna-N Mechanical Seal and O-Ring
- 3/4" NPT Suction and Discharge Ports
- Maximum Working Pressure 50 PSI
- Maximum Temperature 180° F
- Meets U.S. Coast Guard (USCG) Electrical Standards for Ignition Protection on Gasoline Powered Vessels (Title 33, Chapter 1, Part 183, Subpart 1)
- Available in 1/12 HP, 12V DC (4850-97) or 1/12 HP, 115VAC (4851-97) Motors

Model 4292-96:

- Cast Aluminum Construction
- Buna-N Mechanical Seal and O-Ring
- 1" NPT Suction and Discharge Ports
- Maximum Working Pressure 75 PSI
- Maximum Temperature 180° F
- Carry Handle
- Includes (2) Garden Hose Adapters
- 1/2 HP NEMA 56J Open Drip Proof (ODP) Motor with 8 ft. 115VAC Cord

